

# CUDA GEAR

## Owner's Manual

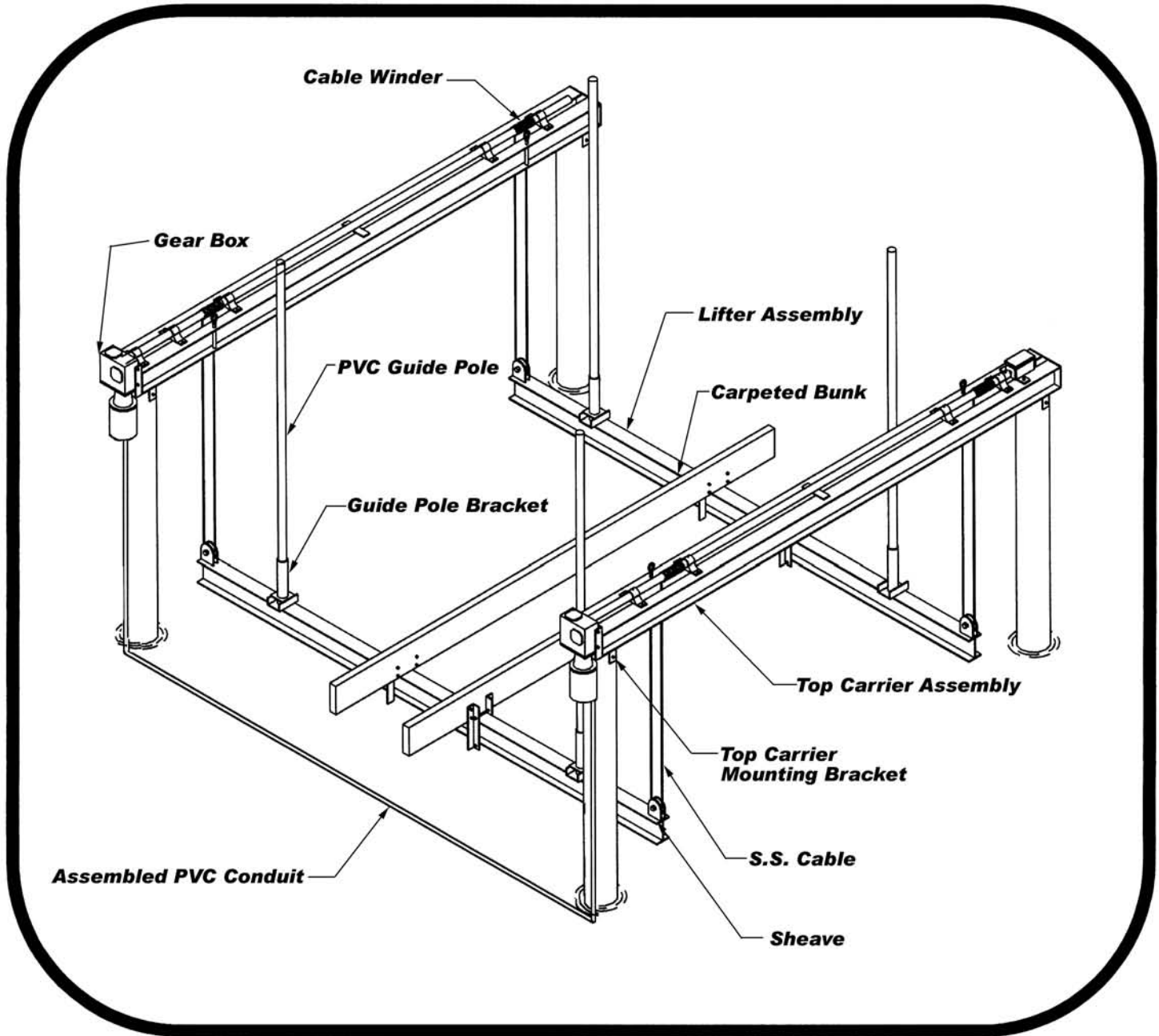

[www.hi-tide.com](http://www.hi-tide.com)

4050 Selvitz Road • Fort Pierce, Florida 34981

(772) 461-4660 1-800-544-0735 Fax (772) 461-2298

# Operation

## THANK YOU

We would like to take a moment to thank you for purchasing a HI-TIDE CUDA GEAR LIFT. We believe our lifts are the easiest to use on the market today, and know that your new lift will give you many years of trouble free service. In the following pages you will find the necessary information for the maintenance of your new lift, as well as instructions on its use. Your new HI-TIDE CUDA GEAR LIFT is the result of over thirty years of extensive research, design and development in south Florida where corrosion, barnacles, and severe weather make lifting boats absolutely necessary. As the leader in the industry, the HI-TIDE CUDA GEAR LIFT offers features provided exclusively by HI-TIDE.

## GENERAL OPERATION:

Upon completion of your lift, the installer will adjust the bunks and guide poles to fit your boat.

- 1) Turn power on to lift.
- 2) Set switches in "DOWN" position and allow lift cradle to sink into water deep enough to clear boat hull and props if necessary.
- 3) Float boat into pick-up position. Guide poles will automatically center boat side-to-side over bunks. The center of gravity of the boat must be over the center of the lift. Normally most of the overhanging portion of the boat will be extended beyond the front of the lift.
- 4) Set switches in "up" position and stand in center of the boat to avoid listing. Maintain fore and aft position and as soon as you feel the bunks contact the boat, set switches to the "off" position and step off the boat.
- 5) Continue to raise boat by setting switches to "up" position. When boat has reached desired storage height above water, set switches to the "off" position.
- 6) Turn power off to lift.

## SAFETY TIPS:

- Keep Children away.
- Do not overload the lift.
- Do not power the boat onto the lift cradle as this will result in damage to the lift and/or boat.
- Do not allow yourself to be distracted or walk away from lift during operation. Failure to shut off lift will result in major damage to the lift and/or boat.
- Do not allow lift to fully contact the sea bed as this will tangle the cables.
- Do not raise cradle closer than 2 feet from top carrier beam.
- Keeps hands and clothing away from all moving parts during operation.
- Lift motors must be stopped completely before activating reversing switches; otherwise lift may continue to move in the same direction.
- Make sure the bilge pump is set for automatic or remove the drain plug. Significant water accumulation in the bilge may overload the lift.
- We recommend that you turn the power off to the lift when you are not boating. When the power is off, no one can steal your boat.
- Lift is not designed for lifting human beings, and no persons should be under the boat while it is in suspended position.

## HELPFUL HINTS:

- A reference mark can be placed on a guide pole to indicate that the lift cradle is deep enough for the boat's hull to clear the cradle. This will assure clearance entering and leaving the cradle as the tide changes.
- For shallow water installations, a reference can be placed on a cable to indicate that the cradle has contacted the seabed. Turning the lift off before this point will prevent the cable winds from becoming tangled

# Lubricant and Preventative Maintenance

Every six (6) months...

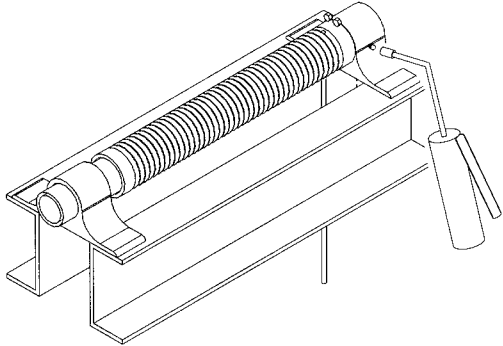

Grease drive shaft bearings with marine grease i.e. Flamingo Maxima E.P.

Every six (6) months...

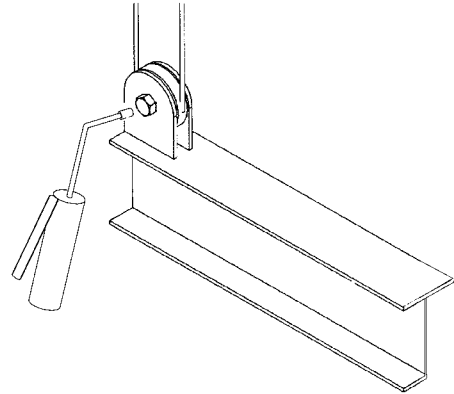

Grease aluminum sheaves (where applicable) with marine grease, i.e. Flamingo Maxima E.P.

Every six (6) months...

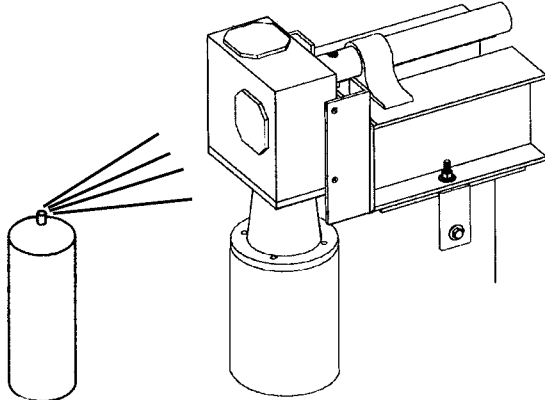

Spray gearbox and motor with a corrosion preventative lubricant, i.e. Corrosion Block

Every six (6) months...

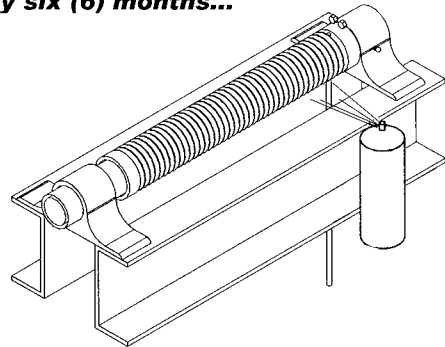

Spray cables and winders with a corrosion preventative lubricant, i.e. Corrosion Block

Every month...

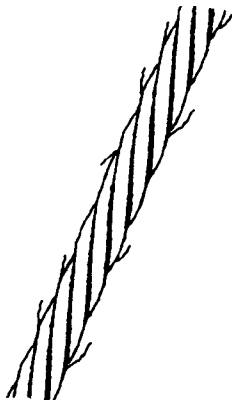

Visually inspect lifting cables for any broken strands (cable fray). If so notify your installer.

Every six (6) months...

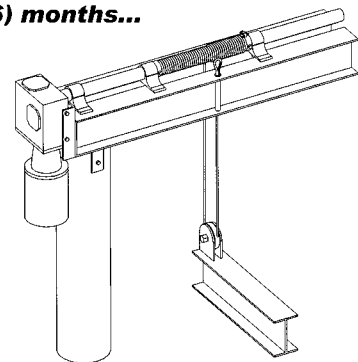

Visually inspect and all working parts for excessive wear, and gearbox for oil leakage. If so notify your installer.

**MAINTENANCE TIP:** To keep your Hi-Tide lift operating at peak performance, minimizing service calls, we recommend that you operate your lift occasionally during the off-season or extended periods of no boating activity. Simply run the lift for approximately one minute in each direction. This will keep the motor contacts and brushes clean and all pulleys and bearings evenly lubricated.

# Warranty

**HI-TIDE SALES, INC. warrants the CUDA GEAR as follows:**

- A) The structural integrity of the aluminum and stainless steel structure members will be free from defects in material and workmanship for a period of (10) TEN years from date of delivery to the original owner. Under no circumstances will this warranty coverage extend to damage by electrolysis and corrosion.**
- B) The gearbox will be free from defects in material and workmanship for a period of FIVE (5) years from date of delivery to the original purchaser.**
- C) The electrical motor will be free from defects in material and workmanship for a period of TWO (2) years from the date of delivery to the original purchaser.**
- D) The remaining components will be free from defects in material and workmanship for a period of ONE (1) year from date of delivery to the original purchaser.**

**Hi-Tide Sales, Inc. agrees to provide the necessary parts and service to the equipment during warranty periods described above; provided HI-TIDE SALES, INC. receives notice of any such defects within the applicable specified warranty periods**

**This warranty shall be deemed void and unenforceable and the equipment shall be deemed sold "AS IS" and "WITH ALL FAULTS", with the entire risk as to quality and performance to be borne by the original purchaser without any implied warranty of fitness or merchantability if any of the following should occur.**

- A) If the equipment should be installed at any location other than the original purchaser's address specified in the sales agreement.**
- B) If the equipment shall be used in any commercial fashion or other than in accordance with the recommendations contained in the operators manual provided to the original purchaser.**
- C) If the equipment is damaged by an event that is not the company's fault; such as, but not limited to, damage caused by accidents, misuse, overloading, negligence, alteration, modification, or abusive operation.**
- D) If the original purchaser or any one not authorized by HI-TIDE SALES, INC. attempts to make any repairs to the equipment.**

**This warranty further does not cover any damages whatsoever including incidental and/or consequential damages resulting from any adverse weather conditions, acts of God or other causes not due to a defect in materials and/or workmanship of the equipment.**

**NOTE: Some states do not allow the exclusion or limitation of incidental or consequential damages so the above limitation or exclusion may not apply to you.**

**The provisions contained in this warranty shall constitute the entire warranty for the equipment. Any statements made relating to the equipment prior to the delivery of this warranty to the original purchaser and any descriptions or other information contained in any brochure describing the equipment are not intended to and do not form any part of the sales agreement and are not part of this warranty and are superseded by the terms of this warranty.**

Effective 12/01/01

## Important Notes

- 1) The installation is completed according to the manufacturer's recommendations.**
- 2) The ultimate user understands how to operate in a safe manner.**
- 3) The ultimate user acknowledges the need for regular service and maintenance of the lifting equipment by an authorized Hi-Tide dealer.**

**No alterations or modifications may be made to Hi-Tide equipment without the expressed written consent of Hi-Tide Sales, Inc. Re-installation of Hi-Tide equipment must be performed by an authorized Hi-Tide Agent/Dealer and must be performed to the standards set forth by Hi-Tide Sales, Inc. Transfer of any remaining warranty to a new location is solely at the discretion of Hi-Tide Sales, Inc. It is the obligation of the re-installer to inform any new operators of the above conditions. Maintenance/Owners Manuals and Safety Warning Decals are available on request from Hi-Tide Sales, Inc.**